



Light Intensity Control (LIC Series)

Disclaimer

- The documentation is provided with the best know-how to the user to operate the LIC to drive the LED intensity.
- The user must ensure that the operation of LIC is suitable for their applications
- The user must ensure the product is applied in the correct way which will not bring any dangerous or damages and cause of financial loss.
- LED Illumination (M) Sdn. Bhd. are not obliged to have responsibility nor compensation for any liability for consequential loss of any damages.

Hardware, software and documentation are Copyright 2009 Led Illumination (M) Sdn. Bhd.

Introduction

The **LIC 256 Series** unit is a Digital Intensity Control with PWM control to drive the LED light source intensity (made by LEDI).

Safety

Please read the Manual before using or do any connection of the LIC 256 Series. If there is any doubt, please contact us for verifications.

- LIC 256 series is take only 12-48VDC input. Please do not connect the input to **AC Current**.
- LIC 256 series is a PWM, constant voltage source; therefore the LED must have a serial resistor to limit the current to prevent damage of the LED. The user must calculate the maximum current which taken by the led and input voltage to determine the resistor value.



Light Intensity Control (LIC Series)

LIC 256 Series Specifications

1. **Intensity control:** 120 KHz PWM frequency and the duty cycle is an adjustable from 0-100% via (0-255 steps).
2. **External Control:** The LIC unit have the interface ability to connect to:
 - i. Serial Control - able to interface with the PC (COM port or RS232).
 - ii. IO Control - able to interface with most of the industrial input/output card with build in an opto-isolator.
3. **Enable consistent image contrast:** The image capturing (pixel consistency <3 pixels value). This will help to improve vision inspection results (to achieve higher accuracy typically in gauging, blob analysis and PRS system).
4. **Protection:** There are two protection circuitry designs in for LIC series.
 - i. **High Side-** An Internal circuit cut off the current if the positive short circuit to external ground. Current will restore back to normal if short circuit is release to normal condition.
 - ii. **Low Side-** An Internal circuit limits the current if the load is short circuit.
5. **Driver:** High power MOSFET is used to drive the output and guarantee to have long operating hours (100,000).
6. **Intensity Linearity:** The intensity is set by digitally (soft touch switch from the panel or control through the RS232). Therefore, the output current is linear and each of the step is:
 - i. **256 Steps** – 0.39%/step (0-100% intensity).
7. **Input Voltage Requirement:**
 - i. **Normal - 12-24VDC ONLY.** (LIC-2256-U or LIC-4256-U)
****Please aware on the MAX. Input voltage for light head.
 - ii. **Strobe – 12-48VDC.** (LIC-2256-SU or LIC-4256-SU)
8. **Power Dissipation:**  The LIC 256 series is able to drive up to maximum output of 40W/ Channel. But when the LIC 256 series is driving to maximum power rating, a significant heat will be generated from the driver and heat up the case. The user must ensure the LIC case have a proper heat dissipation to release heat.



Light Intensity Control (LIC Series)

9. Mechanical Dimension

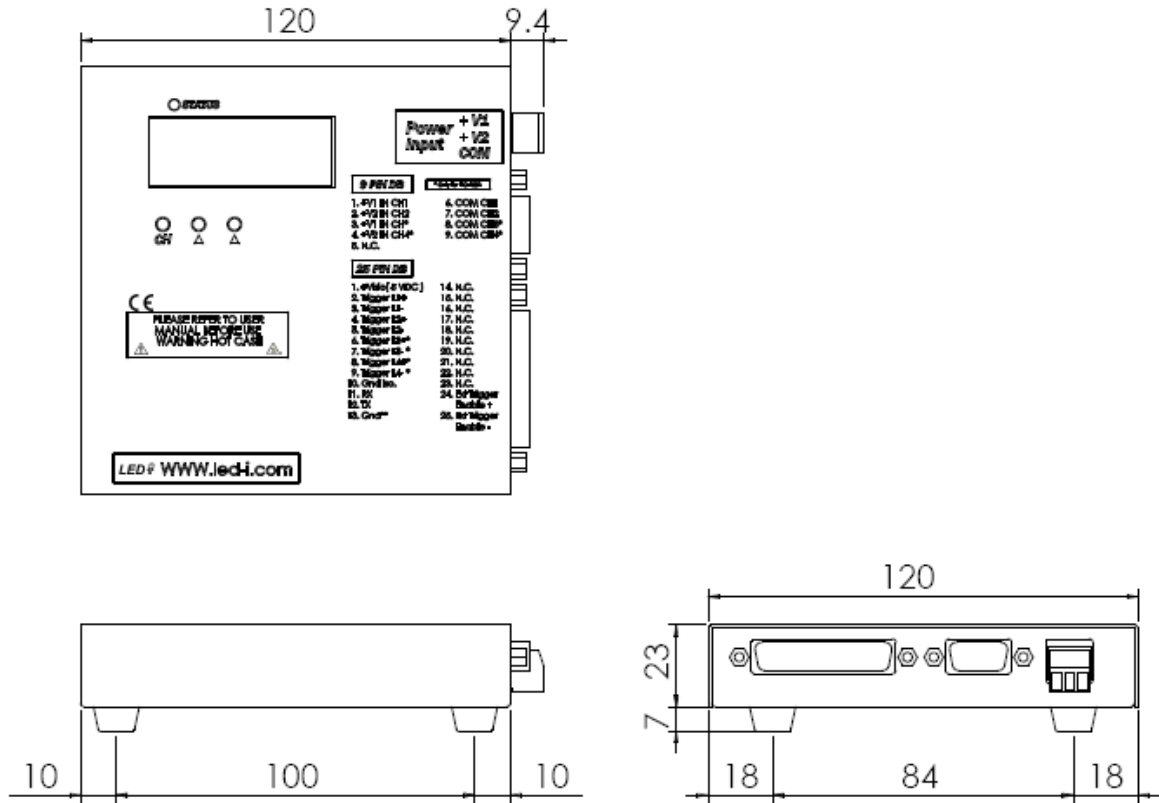

All dimension area in mm.

10. Intensity Setting:

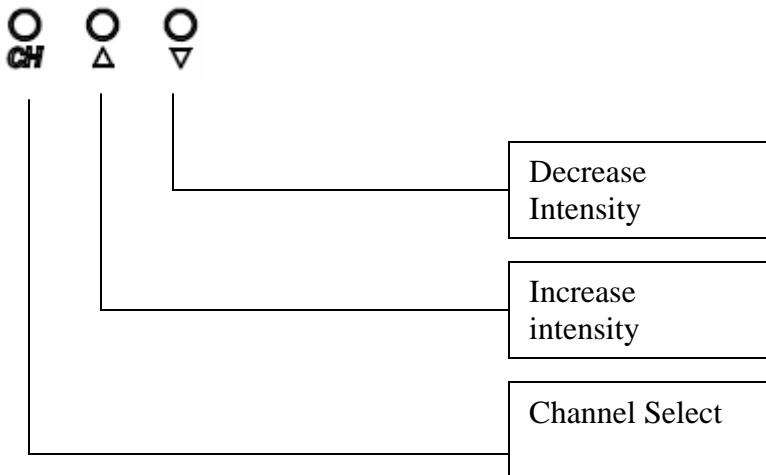



Light Intensity Control (LIC Series)

11. Connection: External strobe light control. (EXT)

- i. **External strobe light control-** trigger by external to flash the light head.
- ii. **Flash duration control-** A maximum flash pulse (light output) is limit to 7.5msec or the flash period is depends on trigger pulse duration if the trigger input pulse is less than (<7.5msec).

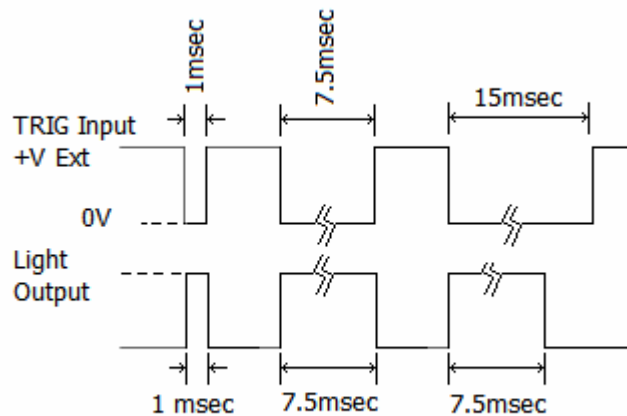

- iii. **Intensity on external control-** refers to control panel setting.

Trigger Timing Trigger Circuit

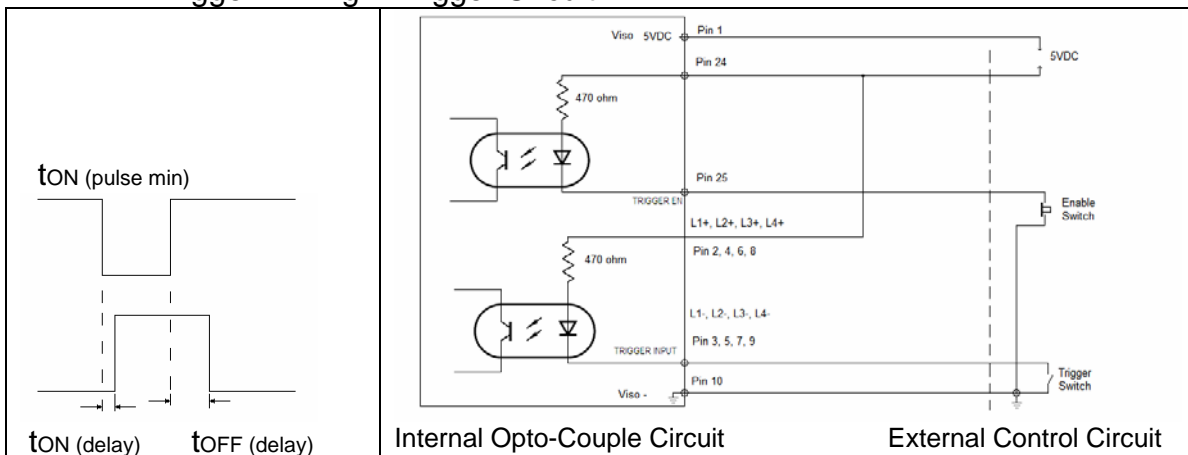

- $t_{ON} \text{ (pulse min)}$ = 10usec
- $t_{ON} \text{ (delay)}$ = 2usec
- $t_{OFF} \text{ (delay)}$ = 30usec



Light Intensity Control (LIC Series)

11.1 Power Input

The LIC-X256 series take in 12-48VDC only.



Pins	Descriptions
+V1	Supply for Channel 1,3
+V2	Supply for controller and also Channel 2,4
Com	Common for the controller

Channel 1, 3 can be power at one DC voltage.
Channel 2, 4 can be power at another DC voltage.

11.2 Connector Pin Configuration

	Pin	Signals Name	Pin	Signals Name
	1	+V1 CH1	6	COM CH1
	2	+V2 CH2	7	COM CH2
	3	+V1 CH3	8	COM CH3
	4	+V2 CH4	9	COM CH4
5	N.C.			

DB-9 pin Female



Light Intensity Control (LIC Series)

	Pin	Signals Name	Pin	Signals Name
	1	+Viso(5 VDC)	14	N.C.
	2	Trigger L1+	15	N.C.
	3	Trigger L1 -	16	N.C.
	4	Trigger L2+	17	N.C.
	5	Trigger L2 -	18	N.C.
	6	Trigger L3+	19	N.C.
	7	Trigger L3 -	20	N.C.
	8	Trigger L4+	21	N.C.
	9	Trigger L4 -	22	N.C.
	10	Gnd iso.	23	N.C.
	11	RX (See figure 10)	24	Ext Trigger Enable +
	12	TX (See figure 10)	25	Ext Trigger Enable -
13	Gnd **			

DB-25 pin Female

** This ground should not use for trigger signals. Only use for PC Serial port connection.



Light Intensity Control (LIC Series)

11.3 Connection with AVT Guppy Camera

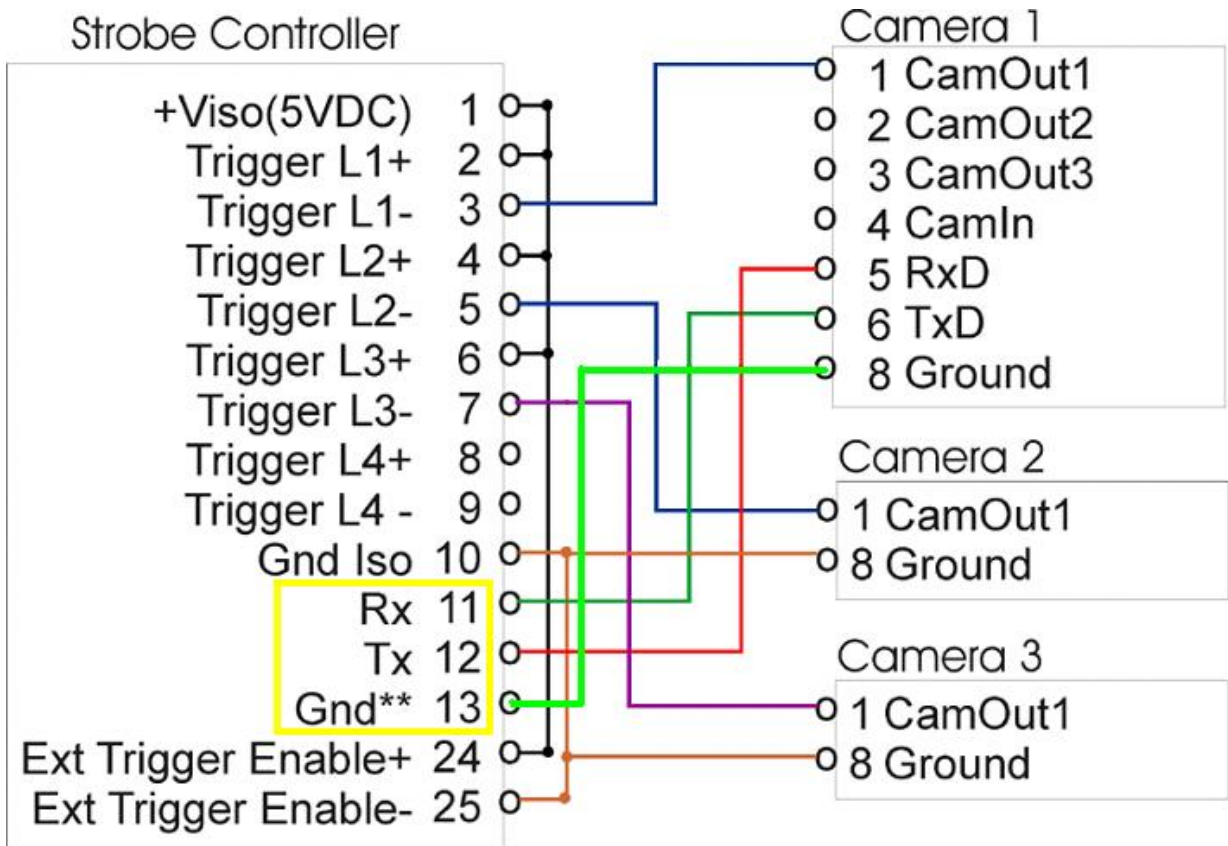



Light Intensity Control (LIC Series)

12. Serial Port Control

The LIC is able to control thru serial communication.

12.1 Power Up

LIC unit will send 3AH thru TX to PC to indicate LIC-X256 unit has ready to receive the control data from PC.

12.2 Data Protocol for setting the intensity.

Two byte is required to send to LIC-4256/LIC-2256. The first byte is the LIC signature code and the second byte is indicates the intensity. For example:

Example:

Software Control

